

Technisches Datenblatt :

rentit

MSI 30 ST5

Manitou MSI 30 D K ST5 S1 -

3F4700/CS



 **MANITOU**
HANDLING YOUR WORLD

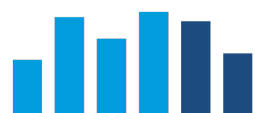

Technical characteristics		Metrisch	
1.1	Manufacturer		Manitou
1.2	Model Name		MSI 30 ST5
1.3	Power source		Diesel
1.4	Operator type		Seated
1.5	Max. capacity	Q	3000 kg
1.6	Load center of gravity	c	500 mm
1.8	Load distance, centre of drive axle to fork	x	626 mm
1.9	Wheelbase	y	1900 mm
	Standard mast reference of the machine		FVD 33
Weight			
2.1	Service weight		4400 kg
2.2	Weight on front axle (laden) / rear axle (laden)		6560 kg / 840 kg
2.3	Weight on front axle (Unladen) / rear axle (Unladen)		1660 kg / 2740 kg
Wheels			
3.1	Tires type		Pneumatic
3.2	Dimensions of front wheels		300-15/18 6T P43
3.3	Dimensions of rear wheels		7.00-12/12 ED PLUS
3.5	Number of front wheels / rear wheels		2 / 2
3.5.2	Number of drive wheels		2
3.6	Front wheel gauge	b10	1044 mm
3.7	Rear wheel gauge	b11	1108 mm
Dimensions			
4.7	Height of overhead guard (cabin)	h6	2095 mm
4.8	Seat height/stand height	h7	972 mm
4.19	Overall length	l1	4234 mm
4.20	Length to face of forks	l2	3034 mm
4.21	Overall width	b1	1330 mm
4.22	Forks section / width / length	s / e / l	45 mm x 100 mm x 1200 mm
4.23	Fork carriage ISO 2328 (class/form) A/B		3A
4.24	Fork carriage width	b3	1260 mm
4.31	Ground clearance below mast	m1	260 mm
4.32	Ground clearance at centre of wheelbase	m2	238 mm
4.33	Aisle Width for pallets 1000 x 1200 crossways	Ast	4676 mm
4.35	Turning radius	Wa	2650 mm
Performances			
5.1	Travel speed (laden / unladen)		21 km/h-21 km/h
5.2	Lifting speed (laden / unladen)		0.50 m/s-0.50 m/s
5.3	Lowering speed (laden / unladen)		0.50 m/s-0.30 m/s
5.5	Drawbar pull (Laden)		1900 daN
5.7	Gradeability (laden)		27 %
5.10	Service brake		Hydraulic brakes by loss of pressure
Engine			
7.1	Engine brand / model		Kubota / D1803 CRT E5B
7.2	I.C. Engine power rating		37 kW
7.3	Rated speed		2700 rpm
7.4	Number of cylinders / Capacity of cylinders		3 - 1826 cm³
Miscellaneous			
8.1	Type of drive control		Electronic
8.2	Working hydraulic pressure for attachments		220 bar
8.3	Oil flow rate for attachments		45 l/min
8.4	Sound level at the driver's ear according to DIN 12 053		81 dB

MSI 30 ST5 - Maßzeichnung

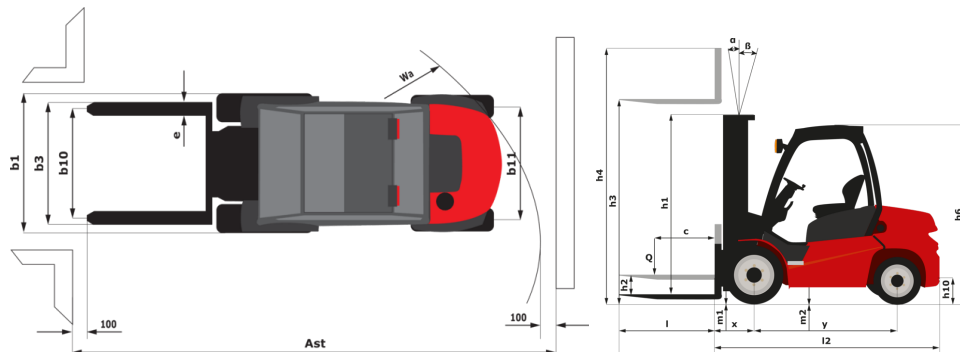

Free Lift Triplex (FLT)	FLT 47
α - Mast/fork carriage tilt, forward	° 12
β - Mast/fork carriage tilt, backward	° 10
h1 - Mast lowered height	mm 2386
h2 - Mast free lift	mm 1658
h3 - Mast lifting height	mm 4700
h4 - Mast extended height	mm 5484
Residual capacity at max height	kg 2700
Residual capacity with hooked-on side shift at max height	kg 2350
Height at max capacity	mm 4300
Height at max capacity with hooked-on sideshift	mm 4200

