

|                     |                |                                             |                |            |              |
|---------------------|----------------|---------------------------------------------|----------------|------------|--------------|
| Distinguishing mark | 1.1            | Manufacturer                                |                |            | EP           |
|                     | 1.2            | Model designation                           |                |            | EFL252       |
|                     | 1.3            | Drive                                       |                |            | Electric     |
|                     | 1.4            | Operator type                               |                |            | Seated       |
|                     | 1.5            | Load capacity                               | Q              | kg         | 2500         |
|                     | 1.6            | Load center distance                        | c              | mm         | 500          |
|                     | 1.8            | Load distance, centre of drive axle to fork | x              | mm         | 495          |
|                     | 1.9            | Wheelbase                                   | y              | mm         | 1595         |
|                     | Service weight | 2.1                                         | Service weight |            | kg           |
| 2.2                 |                | Axle loading, laden front/rear              |                | kg         | 5530/800     |
| 2.3                 |                | Axle loading, unladen front/rear            |                | kg         | 1480/2350    |
| Tyres/chassis       | 3.1            | Tyre type                                   |                |            | Solid rubber |
|                     | 3.2            | Tyre size, front                            |                |            | 7.00-12      |
|                     | 3.3            | Tyre size, rear                             |                |            | 6.00-9       |
|                     | 3.5            | Wheels, number front/rear (x=drive wheels)  |                | mm         | 2x/ 2        |
|                     | 3.6            | Tread width, front                          | b10            | mm         | 970          |
|                     | 3.7            | Tread width, rear                           | b11            | mm         | 975          |
| Dimensions          | 4.1            | Tilt of mast/fork carriage forward/backward | $\alpha/\beta$ | °          | 6/ 10        |
|                     | 4.2            | Retracted mast height                       | h1             | mm         | 2200         |
|                     | 4.3            | Free lift                                   | h2             | mm         | 1650         |
|                     | 4.4            | Lift height                                 | h3             | mm         | 4800         |
|                     | 4.5            | Height, mast extended                       | h4             | mm         | 5365         |
|                     | 4.7            | Height of overhead guard (cabin)            | h6             | mm         | 2160         |
|                     | 4.8            | Seat height/standing height                 | h7             | mm         | 1095         |
|                     | 4.12           | Tow coupling height                         | h10            | mm         | 435          |
|                     | 4.19           | Overall length                              | l1             | mm         | 3573         |
|                     | 4.20           | Length to face of forks                     | l2             | mm         | 2503         |
|                     | 4.21           | Overall width                               | b1/b2          | mm         | 1154         |
|                     | 4.22           | Fork dimensions                             | s/e/l          | mm         | 40x122x1070  |
|                     | 4.23           | A,B Fork carriage class/type A, B           |                |            | 2A           |
|                     | 4.24           | Fork carriage width                         | b3             | mm         | 1090         |
|                     | 4.31           | Ground clearance, laden, below mast         | m1             | mm         | 100          |
|                     | 4.32           | Ground clearance, center of wheelbase       | m2             | mm         | 150          |
|                     | 4.34.1         | Aisle width for pallets 1000x1200 crossways | Ast            | mm         | 3985         |
|                     | 4.34.2         | Aisle width for pallets 800x1200 crossways  | Ast            | mm         | 4195         |
|                     | 4.35           | Turning radius                              | Wa             | mm         | 2290         |
| Performance data    | 5.1            | Travel speed, laden/unladen                 |                | km/h       | 11/12        |
|                     | 5.2            | Lifting speed, laden/unladen                |                | m/s        | 0.28/0.37    |
|                     | 5.3            | Lowering speed, laden/unladen               |                | m/s        | 0.45/0.5     |
|                     | 5.5            | Drawbar pull, laden/unladen                 |                | N          | —            |
|                     | 5.6            | Max. drawbar pull, laden/unladen            |                | N          | —            |
|                     | 5.8            | Max. gradeability, laden/unladen            |                | %          | 15/15        |
|                     | 5.10           | Service brake                               |                |            | Hydraulic    |
| 5.11                | Parking brake  |                                             |                | Mechanical |              |
| Electric-engine     | 6.1            | Drive motor rating S2 60 min                |                | kW         | 10           |
|                     | 6.2            | Lift motor rating at S3 15%                 |                | kW         | 16           |
|                     | 6.4            | Battery voltage/nominal capacity            |                | V/Ah       | 80V205AH     |
|                     | 6.5            | Battery weight                              |                | kg         | —            |
| Addition data       | 8.1            | Type of drive control                       |                |            | AC           |
|                     | 10.5           | Steering design                             |                |            | Hydraulic    |
|                     | 10.7           | Sound pressure level at the driver's ear    |                | dB(A)      | < 74         |

| Mast types | Lift height (h3) | Height, Mast             |                           |               | Height, Free lift(h2) |               |
|------------|------------------|--------------------------|---------------------------|---------------|-----------------------|---------------|
|            |                  | Height, mast lowered(h1) | Height, mast extended(h4) |               | No shelving           | With shelving |
|            |                  |                          | No shelving               | With shelving |                       |               |
|            | mm               | mm                       | mm                        | mm            | mm                    | mm            |

3-Free Mast

4800

2220

5365

5825

1655

1185



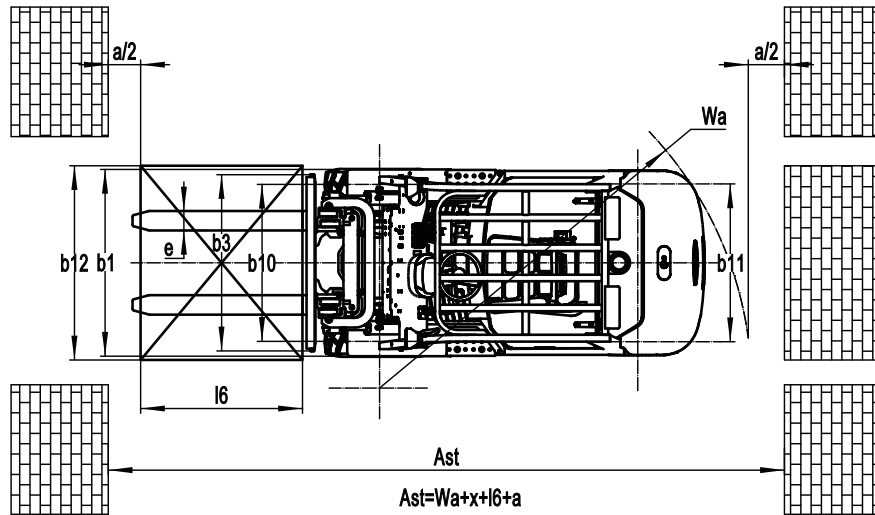
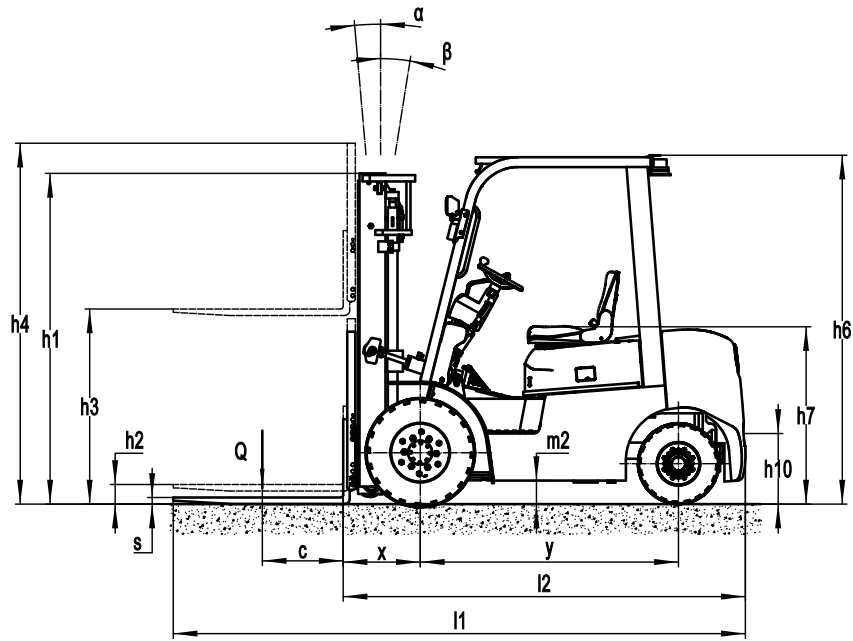

### RATED CAPACITIES

