

**MTE230**

	23,00 m		21,00 m		10,60 m (300 kg) 12,70 m (200 kg) 16,00 m (100 kg)
	300 kg		1,40x0,70x1,10 m		90°+90°
	450°		EX Stabilizzatori a estensione laterale idraulica Stabs par vérins extensibles hydrauliquement Laterally extensible hydraulic stabilizers H-Abstützung		3,5 t

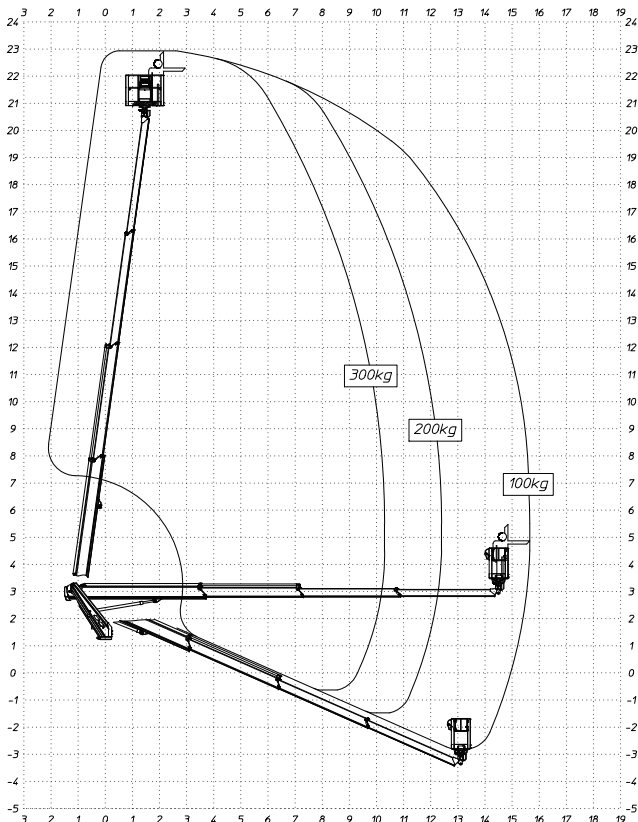

Vollabstützung über Heck

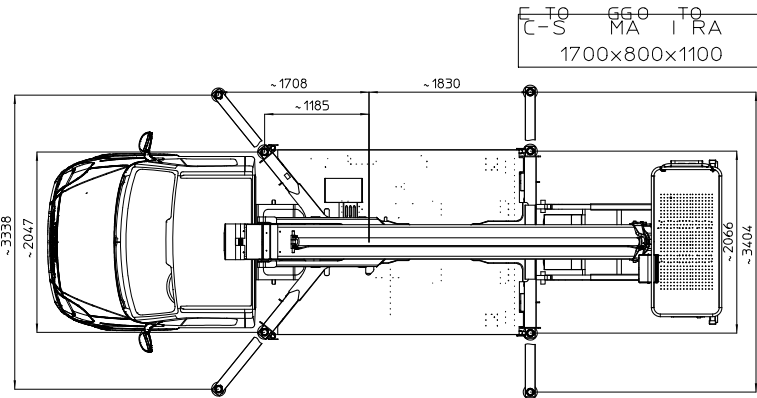
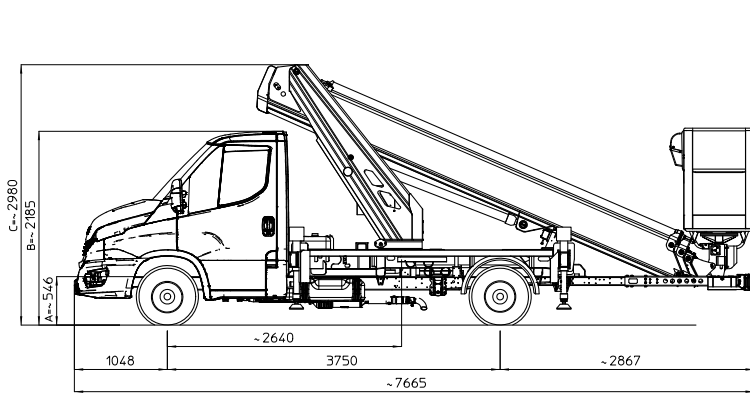
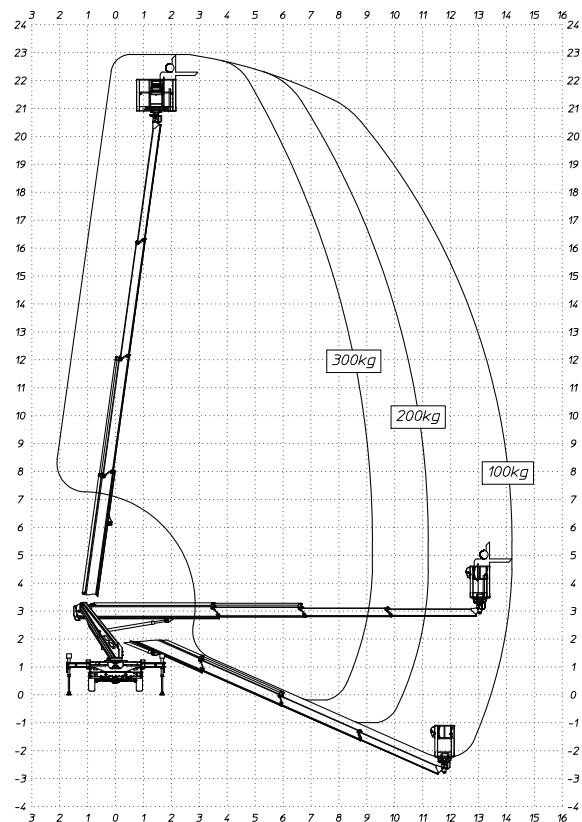

Vollabstützung über Seite

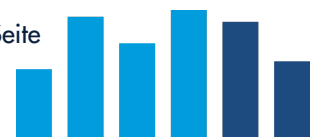

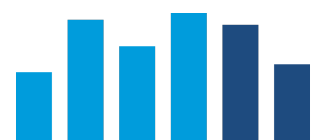
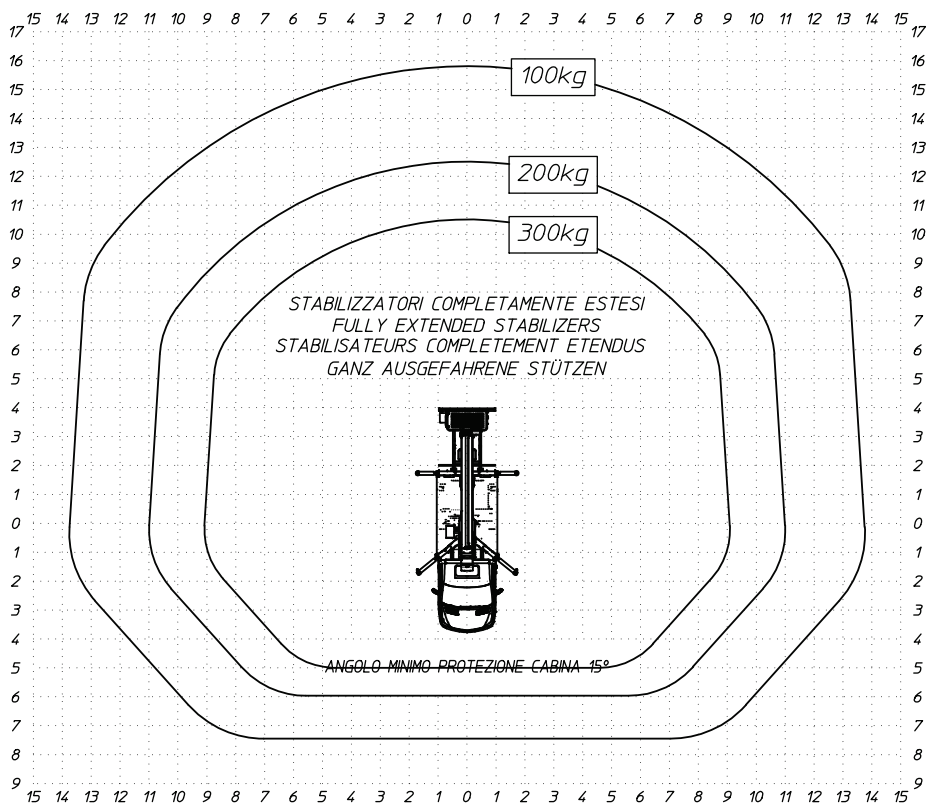
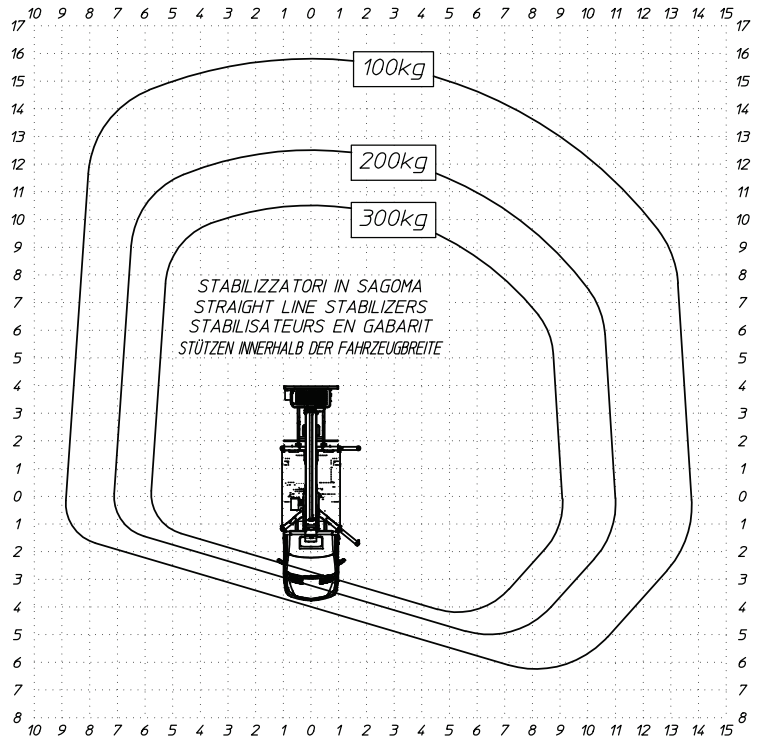
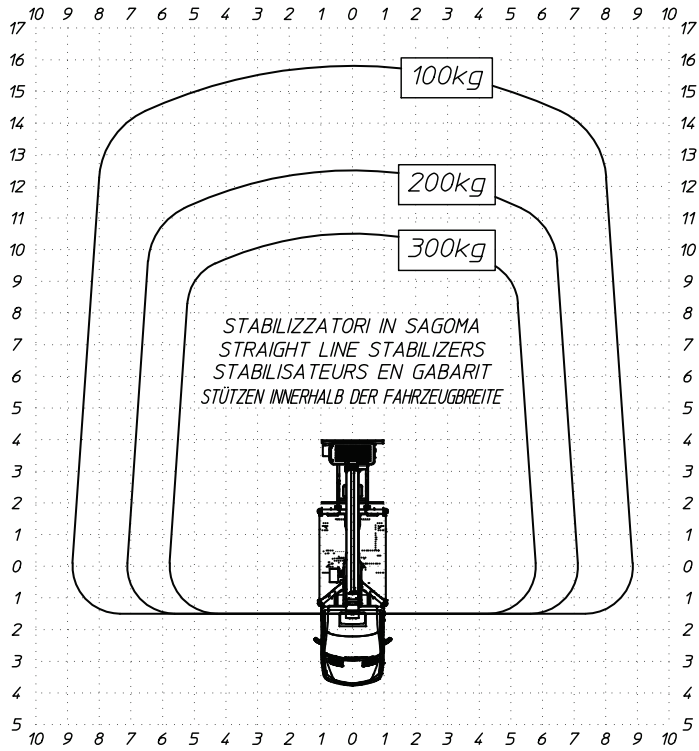

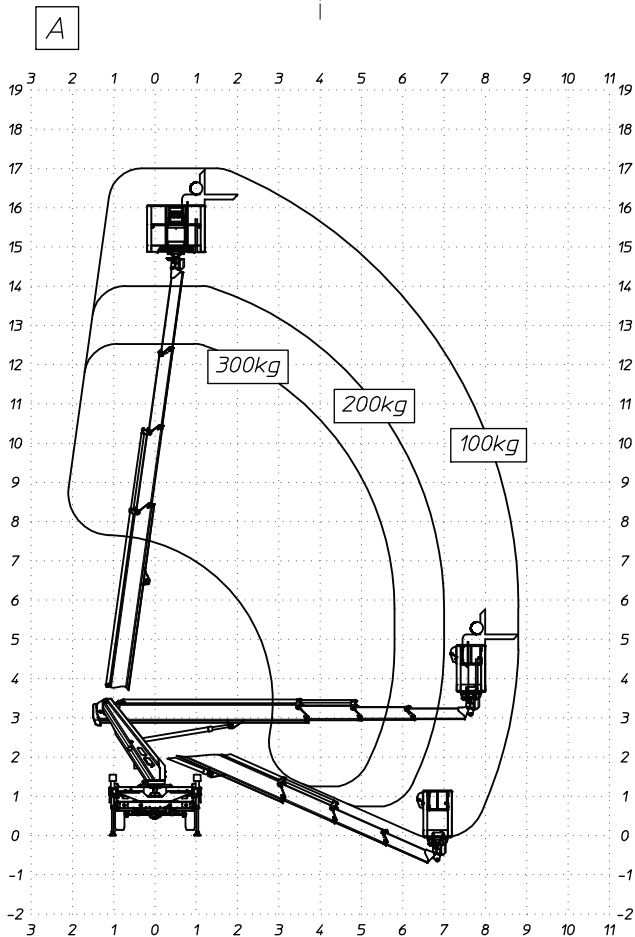
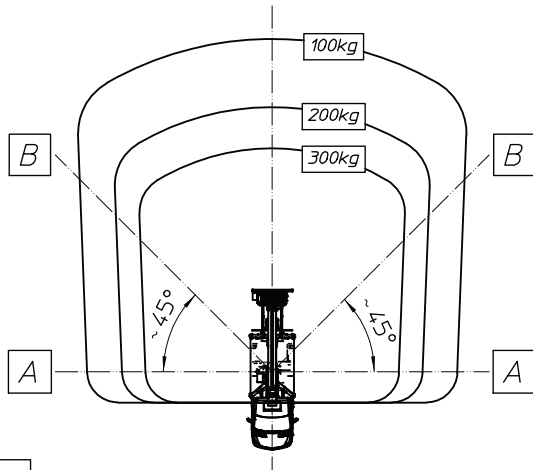

Minimalabstüzung über Seite

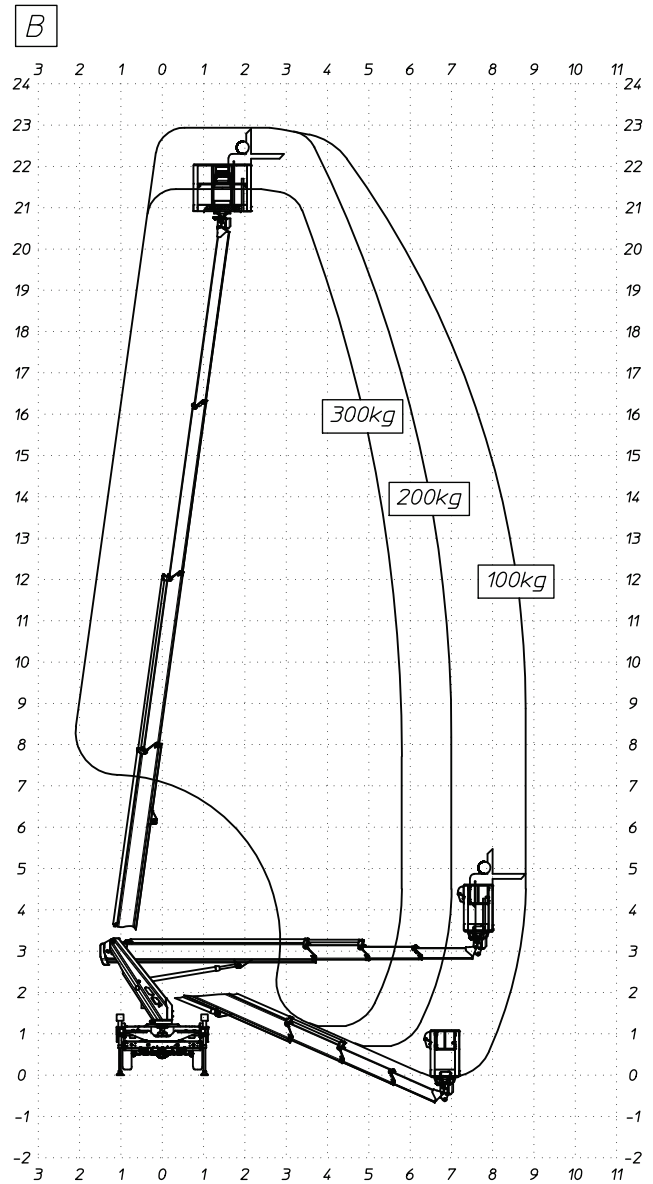

Minimalabstüzung über Heck

